

high-temperature filters

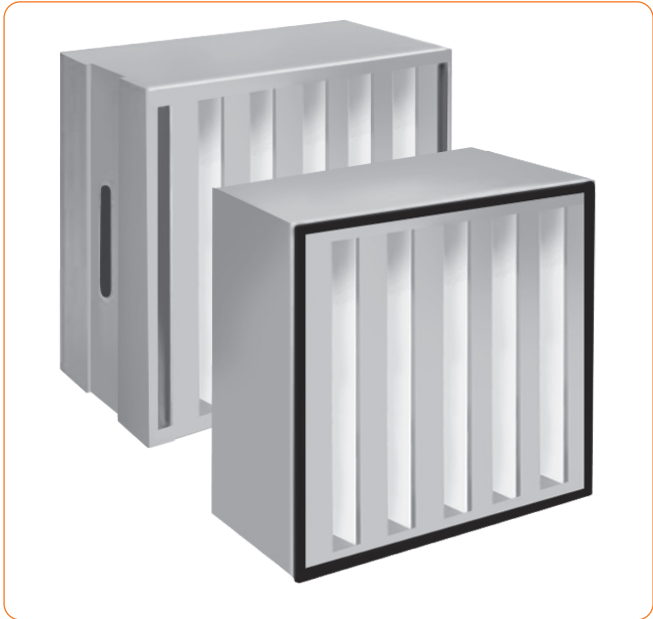

UltraMet V292 HT



Filtration material:	glass fiber (glass microfibers)
Separators:	hot melt
Casing:	galvanized or stainless steel
Bonding:	two-component cold-mixed (polyurethane),
Sealing gasket:	on one side of the filter (continuous foam or flat)
Operating temperature:	120°C
*Final pressure drop derived from the filter test standard:	500 Pa

1. Operating temperature to 120°C
2. Durable and rigid construction
3. High dust absorbency
4. Low pressure drop
5. Long filter lifespan
6. Low energy costs
7. Resistance to humidity
8. Flame retardant (FI acc. DIN 53438)

Application: high-temperature filters for 120°C are used in production processes where hot purified air is required. They are most commonly used in the pharmaceutical and food industries in conditions where they are tasked with filtering very large volumes of air while maintaining a high level of air purity. The V-shaped design technology is characterized by a large filtration area and low air flow resistance.

* The final operating pressure drop of the filters should be checked in the technical documentation or consulted with the manufacturer of the equipment being operated.

* All technical parameters provided in this specification are for informational purposes only. Actual values may differ by up to ±10% from the stated figures. The manufacturer assumes no responsibility for any consequences arising from the selection of filters in non-standard sizes based solely on the user's own calculations.

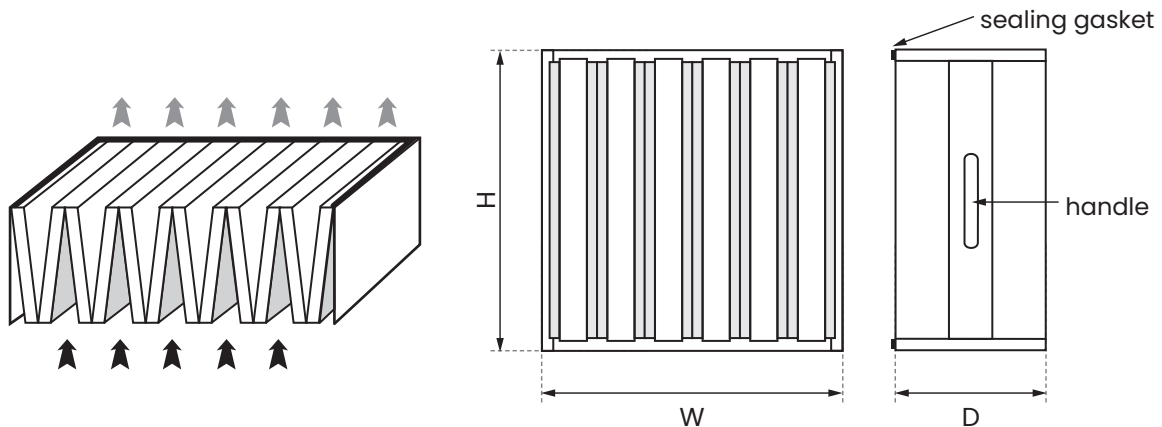

We reserve the right to make changes to the technical specifications at any time without prior notice, resulting from the continuous improvement of our products.