

carbon filters

UltraSorb C150

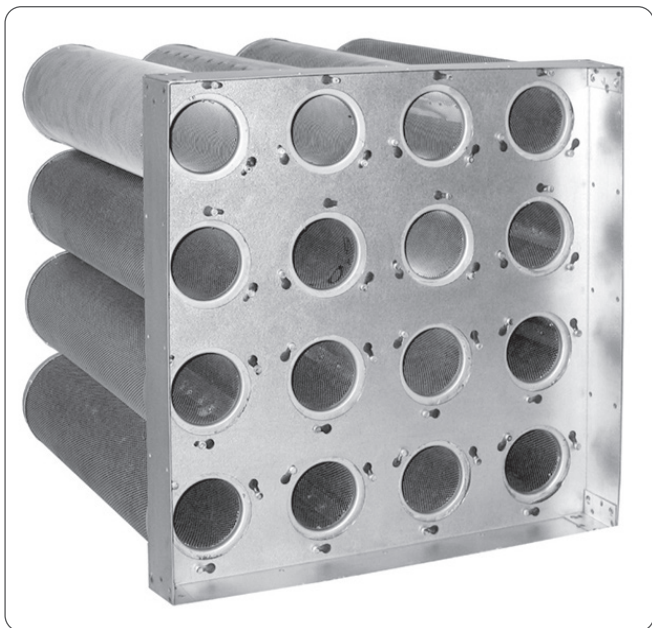

Filtration material: high-quality granulated activated carbon with high capacity of adsorption.

Grain diameter up to 4 mm.

Construction: the casing is made of steel in the form of a tube with one side blanked off.

The tubes come in two lengths and they are mounted in special assembly frames.

Application: activated carbon filters are used for odor removal, i.e. deodorization in air conditioning and ventilation systems, kitchen installations, paint shops, and industrial installations.

They purify the air to remove solvents, hydrocarbons and organic compounds. They also purify other gases which includes exhaust gas desulfurization, removal of dioxins, mercury and other pollutants from exhaust gases.

Ultra Sorb C150 filters are not recommended for use in environments with elevated temperature or humidity levels due to the decreasing sorption capacity.

1. Activated carbon filters
2. Durable construction
3. Air deodorization
4. Long filter lifespan
5. Low energy costs
6. PZH certificate

* The final operating pressure drop of the filters should be checked in the technical documentation or consulted with the manufacturer of the equipment being operated.

131

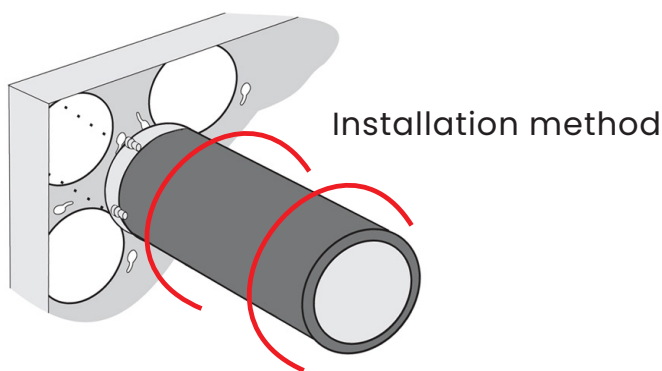

We reserve the right to make changes to the technical specifications at any time without prior notice, resulting from the continuous improvement of our products.

Technical data for various models of the UltraSorb C150 carbon filter

Filter Type	Dimensions [mm]			Carbon Quantity [kg]	Contact Time / Pressure Drop in the Filter							
	W	H	D		for Q=850 m ³ /h		for Q=1700 m ³ /h		for Q=2550 m ³ /h		for Q=3400 m ³ /h	
C 150/250-8	305	610	250	9,2	0,08 s	91 Pa	0,04 s	286 Pa	-	-	-	-
C 150/250-16	610	610	250	18,4	0,16 s	32 Pa	0,08 s	93 Pa	0,06 s	186 Pa	0,04 s	308 Pa
C 150/450-8	305	610	450	16,8	0,14 s	45 Pa	0,07 s	149 Pa	0,05 s	314 Pa	-	-
C 150/450-16	610	610	450	33,6	0,28 s	16 Pa	0,14 s	49 Pa	0,09 s	101 Pa	0,07 s	171 Pa
C 150/600-8	305	610	600	24	0,19 s	35 Pa	0,10 s	122 Pa	0,06 s	261 Pa	0,05 s	458 Pa
C 150/600-16	610	610	600	48	0,38 s	12 Pa	0,20 s	39 Pa	0,12 s	82 Pa	0,10 s	144 Pa

Dimensions

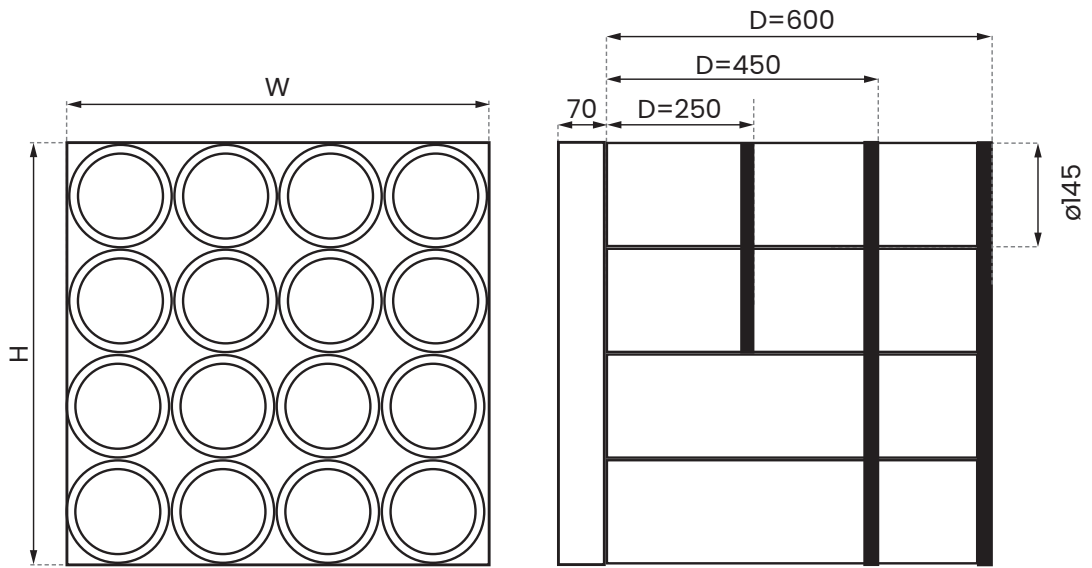

Air flow diagram for carbon filter UltraSorb C150

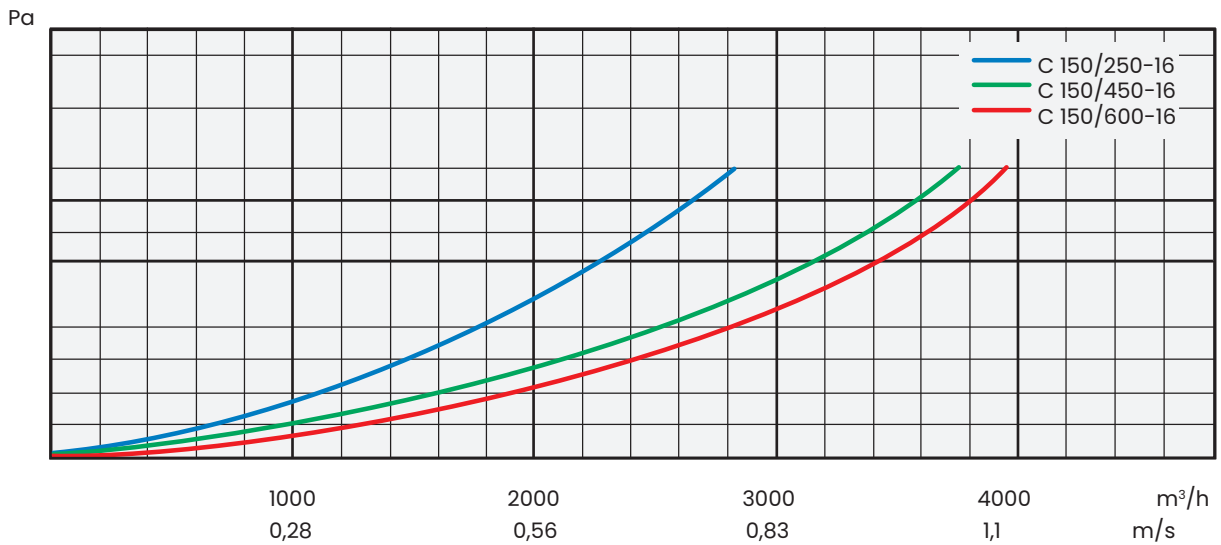

We reserve the right to make changes to the technical specifications at any time without prior notice, resulting from the continuous improvement of our products.